

FEATURES

- Medium Power Output: $P_{1dB}=21.5dB$ (Typ.)@8.0GHz
- High Power Gain: $G_{1dB}=11dB$ (Typ.)@8.0GHz
- Hermetic Metal/Ceramic Package
- Proven Reliability

DESCRIPTION

The FSX017WF is a general purpose GaAs FET designed for medium power applications up to the 12GHz. These devices have a wide dynamic range and are suitable for use in medium power, wide band, linear drive amplifiers or oscillators.

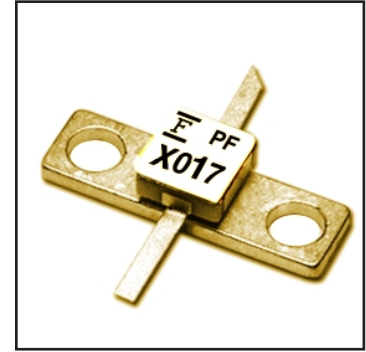

Fujitsu's stringent Quality Assurance Program assures the highest reliability and consistent performance.

ABSOLUTE MAXIMUM RATING (Ambient Temperature $T_a=25^\circ C$)

Item	Symbol	Condition	Rating	Unit
Drain-Source Voltage	V_{DS}		12	V
Gate-Source Voltage	V_{GS}		-5	V
Total Power Dissipation	P_{tot}	$T_c = 25^\circ C$	1.0	W
Storage Temperature	T_{stg}		-65 to +175	$^\circ C$
Channel Temperature	T_{ch}		175	$^\circ C$

Fujitsu recommends the following conditions for the reliable operation of GaAs FETs:

1. The drain - source operating voltage (V_{DS}) should not exceed 8 volts.
2. The forward and reverse gate currents should not exceed 0.7 and -0.1 mA respectively with gate resistance of 2000 Ω .
3. The operating channel temperature (T_{ch}) should not exceed 145 $^\circ C$.

ELECTRICAL CHARACTERISTICS (Ambient Temperature $T_a=25^\circ C$)

Item	Symbol	Test Conditions	Limit			Unit	
			Min.	Typ.	Max.		
Saturated Drain Current	I_{DSS}	$V_{DS} = 3V, V_{GS} = 0V$	35	55	75	mA	
Transconductance	g_m	$V_{DS} = 3V, I_{DS} = 27mA$	-	50	-	mS	
Pinch-off Voltage	V_p	$V_{DS} = 3V, I_{DS} = 2.7mA$	-0.7	-1.2	-1.7	V	
Gate Source Breakdown Voltage	V_{GSO}	$I_{GS} = -2.7\mu A$	-5.0	-	-	V	
Noise Figure	NF	$V_{DS} = 3V, I_{DS} = 10mA$ $f = 8GHz$	-	2.5	-	dB	
Associated Gain	G_{as}		-	10.5	-	dB	
Output Power at 1 dB G.C.P.	P_{1dB}	$V_{DS} = 8V,$ $I_{DS} = 0.7I_{DSS}$	$f = 4GHz$	-	21.5	-	dBm
			$f = 8GHz$	20.5	21.5	-	dBm
			$f = 12GHz$	-	20.5	-	dBm
Power Gain at 1 dB G.C.P.	G_{1dB}	$V_{DS} = 8V,$ $I_{DS} = 0.7I_{DSS}$	$f = 4GHz$	-	15.0	-	dB
			$f = 8GHz$	10.0	11.0	-	dB
			$f = 12GHz$	-	7.5	-	dB
Thermal Resistance	R_{th}	Channel to Case	-	120	150	$^\circ C/W$	

CASE STYLE: WF

G.C.P.: Gain Compression Point

FSX017WF

General Purpose GaAs FET

POWER DERATING CURVE

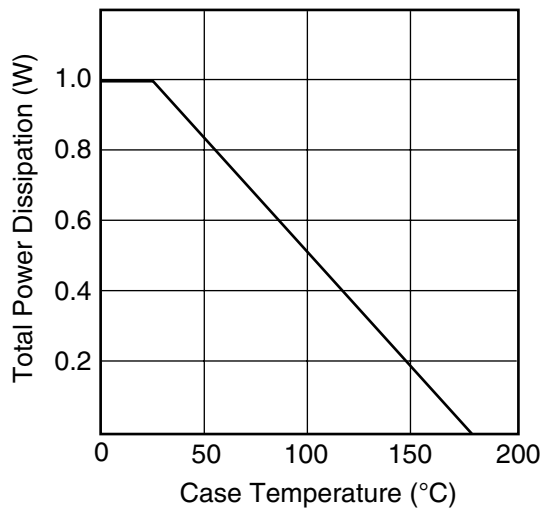

DRAIN CURRENT vs. DRAIN-SOURCE VOLTAGE

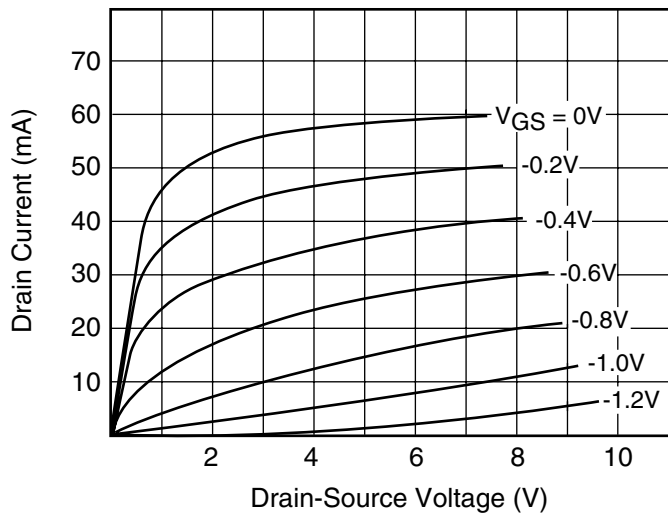

OUTPUT POWER vs. INPUT POWER

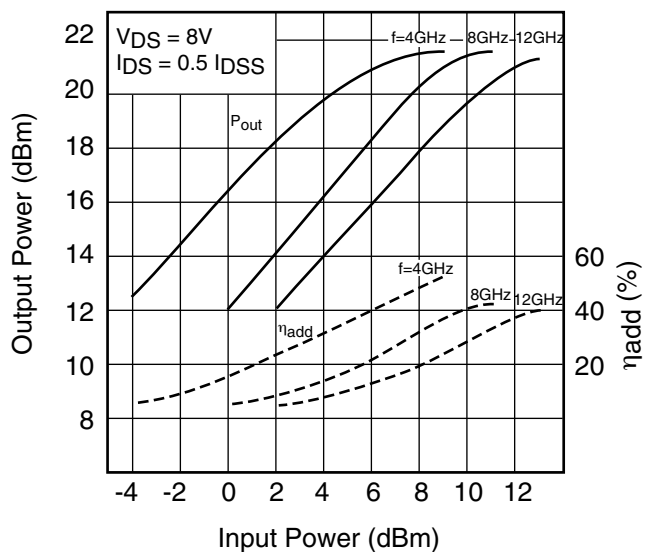

P_{1dB} vs. V_{DS}

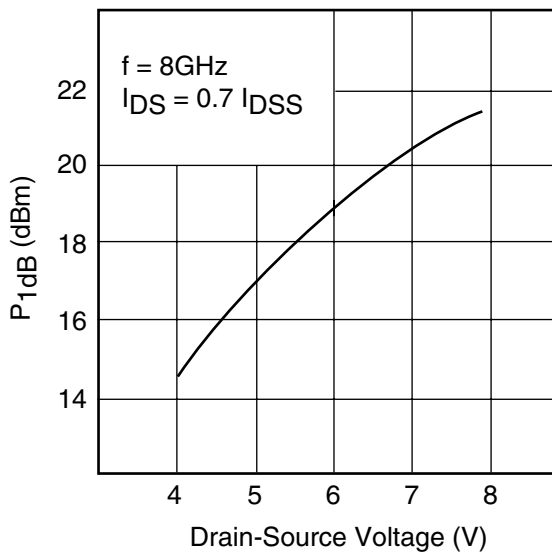

FSX017WF

General Purpose GaAs FET

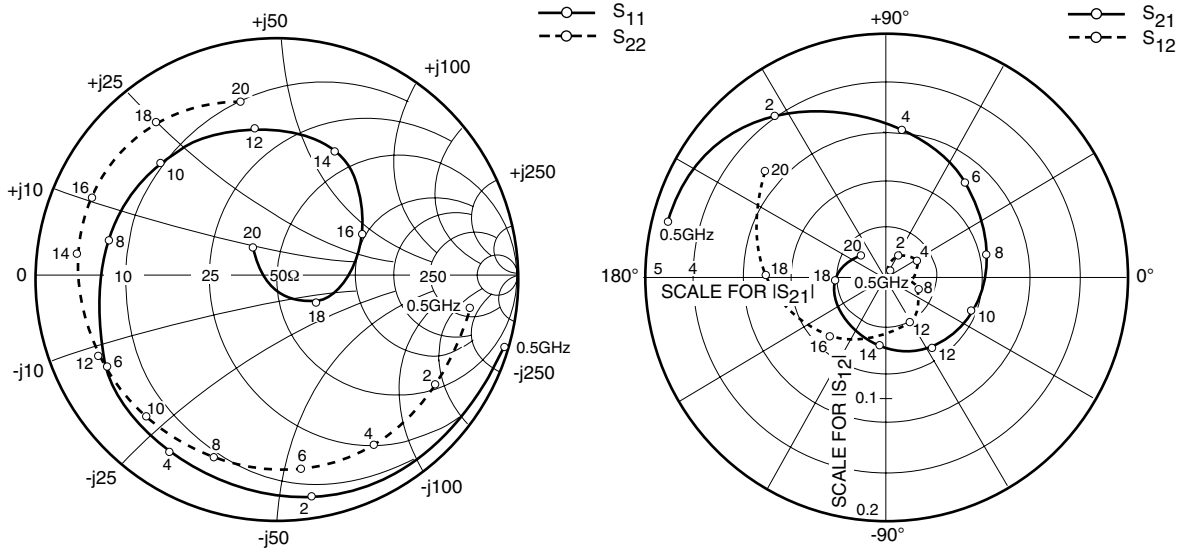

S-PARAMETERS

$V_{DS} = 8V, I_{DS} = 35mA$

FREQUENCY (MHZ)	S11		S21		S12		S22	
	MAG	ANG	MAG	ANG	MAG	ANG	MAG	ANG
500	.994	-17.5	4.666	165.0	.007	75.3	.826	-8.4
1000	.982	-33.7	4.499	151.2	.013	69.9	.819	-17.3
2000	.936	-66.2	4.066	124.2	.022	47.3	.808	-33.3
3000	.891	-92.7	3.486	101.1	.026	30.2	.799	-47.7
4000	.855	-112.9	3.001	82.3	.027	17.5	.796	-59.2
5000	.817	-131.0	2.706	66.1	.026	7.6	.795	-67.5
6000	.778	-150.4	2.555	49.2	.026	0.0	.791	-76.3
7000	.738	-172.0	2.407	30.3	.026	-12.8	.778	-88.8
8000	.705	167.8	2.206	12.0	.022	-20.7	.774	-102.1
9000	.693	150.3	2.020	-5.3	.025	-24.2	.777	-115.7
10000	.679	135.1	1.894	-20.9	.028	-31.8	.780	-127.6
11000	.655	117.2	1.842	-38.1	.035	-43.3	.791	-140.5
12000	.631	96.4	1.750	-57.3	.042	-60.2	.798	-155.2
13000	.610	78.9	1.595	-76.9	.047	-79.6	.809	-173.0
14000	.573	64.6	1.422	-94.9	.050	-96.0	.830	172.1
15000	.503	48.0	1.298	-111.5	.058	-113.5	.846	163.3

FSX017WF

General Purpose GaAs FET

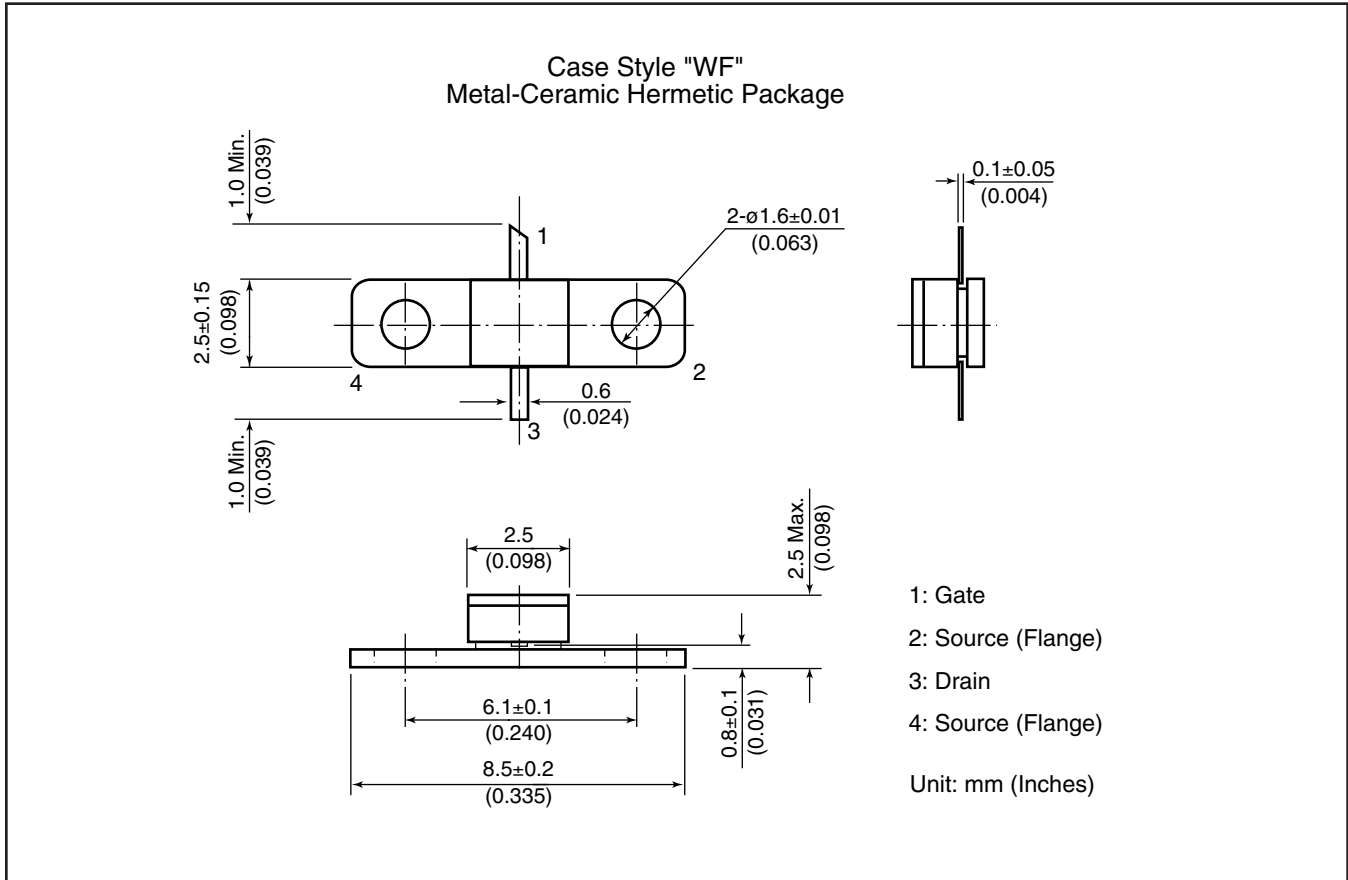

For further information please contact:

FUJITSU COMPOUND SEMICONDUCTOR, INC.

2355 Zanker Rd.

San Jose, CA 95131-1138, U.S.A.

Phone: (408) 232-9500

FAX: (408) 428-9111

www.fcsi.fujitsu.com

FUJITSU MICROELECTRONICS, LTD.

Compound Semiconductor Division

Network House

Norreys Drive

Maidenhead, Berkshire SL6 4FJ

Phone: +44 (0)1628 504800

FAX: +44 (0)1628 504888

CAUTION

Fujitsu Compound Semiconductor Products contain **gallium arsenide (GaAs)** which can be hazardous to the human body and the environment. For safety, observe the following procedures:

- Do not put these products into the mouth.
- Do not alter the form of this product into a gas, powder, or liquid through burning, crushing, or chemical processing as these by-products are dangerous to the human body if inhaled, ingested, or swallowed.
- Observe government laws and company regulations when discarding this product. This product must be discarded in accordance with methods specified by applicable hazardous waste procedures.

Fujitsu Limited reserves the right to change products and specifications without notice. The information does not convey any license under rights of Fujitsu Limited or others.

© 1998 FUJITSU COMPOUND SEMICONDUCTOR, INC.

Printed in U.S.A. FCSI0598M200

This datasheet has been downloaded from:

www.DatasheetCatalog.com

Datasheets for electronic components.